



US PATENT # 6,675,931 B2



**EARTHQUAKE
EARTHQUAKE**

SWS-6.5"

SWS-8"

SWS-10"

SWS-12"

SWS-15"

Installation
Reference Guide

www.earthquakesound.com



DEAR VALUED CUSTOMER

Congratulations are in order... You are now the proud owner of an SWS Shallow Mount Woofer: the most advanced shallow woofer technology to hit car and home audio. The idea is simple: to generate deep bass from the shallowest space. For years, audio manufacturers attempted to reduce the mounting depth of a driver; nevertheless the speaker size/diameter still played a major role in dictating the mounting depth. Approximately, a speaker mounting depth remained to be about $\frac{1}{2}$ the size of the speaker diameter: the larger the speaker the deeper the mounting depth.

Audio, video, and data processing components have gotten better, faster and smaller. This is true except when it comes to speakers design, conventionally designed drivers remain "bulky" in comparison to other audio components. In 1929, Mr. H. Shotwell designed the first "front loaded magnet" driver, it was a small step in reducing the mounting depth of driver. Since then, other audio manufacturers (such as Bose, Harmon and others) made several attempts to reduce the mounting depth of a driver. Nevertheless, the speaker mounting depth remained to be about roughly half the size of the speaker diameter - the larger the speaker the deeper the mounting depth. This "handicap" held true until few years ago when Joseph J. Sahyoun (Vice President, Inventor, and Head Engineer at Earthquake Sound Corporation) started developing the shallow mount woofer system (SWS). The "SWS" presented a radical solution away from the conventional "bulky" speaker design.

The SWS design reduces the mounting depth of a speaker by over 60% without taxing its performance. These numbers look even better as the speaker diameter increases. A conventional 12" woofer has a mounting depth of 6 to 7 inches (for a ± 1 " excursion); on the other hand, an SWS-12 performs the same in a little less than 3" of mounting depth. The SWS design allows the installer to use compact enclosures, whereby the mounting depth is about 1.5 times the peak-to-peak excursion. The SWS technology makes the speaker mounting depth "excursion-dependent" and not "diameter-dependent". Once a target Xmax is set, the mounting depth follows (1.5 times the peak to peak excursion); the Xmax remains independent from the size (diameter) of the speaker. The SWS opens the door for unrestricted bass applications where a conventional subwoofer could never be used.

In home applications, SWS allows the designer to build 12" in wall woofer that moves 2" peak to peak while maintaining a mounting depth of less than 3". This technology opens the door for home theater designers to squeeze large woofers in very tight spaces / closets, also to do in-wall woofer application. In car applications, rear-deck subwoofer mount - used by manufacturers of luxury automobiles- represents a perfect example of a totally stealth install (using 10", 12", 15" SWS). 8" door mount with 1" peak to peak now is possible where mounting depth is a mere 1.5"; with a possibility of using 10" SWS in the doors of larger SUV's.

The aluminum custom-made cone and dust cap are designed to reduce the voice coil temperature by dissipating the heat that builds up in the voice coil. The dust cap is directly fastened to the voice coil aluminum bobbin, it transfers the heat build-up from the bobbin into the cone. Both dust cap and cone act as a giant heat sink to reduce the voice coil temperature and increase its power handling and endurance. The high roll pressed-foam surround is coupled with a propagating spider to allow for extreme excursions with no limitations. The slick shallow basket is coated with black chrome and is shaped with slant edges for easy install in tight spaces.

[Read on...](#)

SWS PARAMETERS

	SWS 6.5"	SWS 8"	SWS 10"	SWS 12"	SWS 15"
Revc. (ohms)	3.600	3.500	3.700	3.700	3.400
Fo. (Hz)	39.31	30.394	28.447	24.006	21.006
Sd. (msqM)	12.500	22.000	33.000	53.000	89.000
BL. (TM)	4.350	6.210	22.095	10.642	10.956
Qms.	4.192	3.987	5.02	3.56	3.847
Qes.	1/723	0.804	0.51	0.515	1.02
Qts.	1.221	0.669	0.46	0.45	0.65
SPLo. (dB)	77.3	86.7	88.2	89.4	90.4
Vas. (Ltr)	9.94	27.830	51.479	149.612	203.112
Xmax. (mm)	15	23	28	31	34

(Xmax measured in one direction)

SPECIFICATIONS

SWS-6.5"

- Speaker diameter = 6.5"
- Mounting depth = 1 3/4"
- Cut out mounting hole = 5 3/4"
- Weight = 5 Lbs
- Voice Coil diameter = 1"
- Aluminum bobin
- Power rating RMS = 100W
- Power rating MAX = 200W
- Revc = 3.6 Ohms

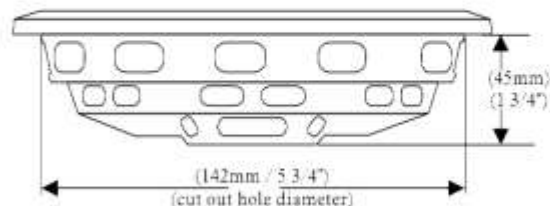

SWS-8"

- Speaker diameter = 8"
- Mounting depth = 2 1/8"
- Cut out mounting hole = 7 7/8"
- Weight = 8 Lbs
- Voice Coil diameter = 1.5"
- Aluminum bobin
- Power rating RMS = 150W
- Power rating MAX = 300W
- Revc = 3.5 Ohms

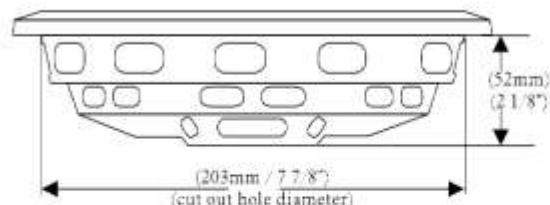

SWS-10"

- Speaker diameter = 10"
- Mounting depth = 2 11/16"
- Cut out mounting hole = 8 7/8"
- Weight = 11Lbs
- Voice Coil diameter = 2"
- Aluminum bobin
- Power rating RMS = 200W
- Power rating MAX = 400W
- Revc = 3.76 Ohms

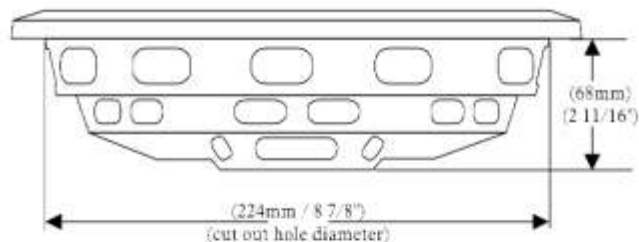

SWS-12"

- Speaker diameter = 12"
- Mounting depth = 3"
- Cut out mounting hole = 11 1/8"
- Weight = 13Lbs
- Voice Coil diameter = 2.5"
- Aluminum bobin
- Power rating RMS = 300W
- Power rating MAX = 600W
- Revc = 3.76 Ohms

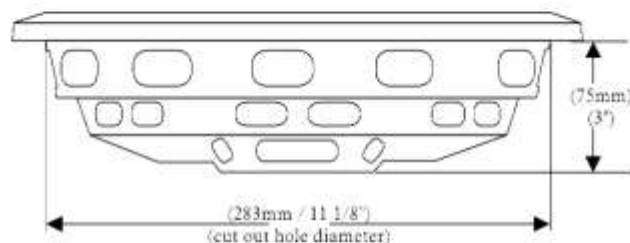

SWS-15"

- Speaker diameter = 15"
- Mounting depth = 3 1/4"
- Cut out mounting hole = 11 1/8"
- Weight = 15Lbs
- Voice Coil diameter = 2.5"
- Aluminum bobin / wire
- Power rating RMS = 400W
- Power rating MAX = 800W
- Revc = 3.76 Ohms

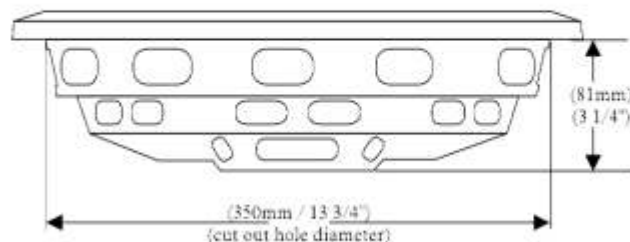

SWS-6.5" RECOMMENDED APPLICATION

The SWS-6.5 woofer is designed to replace any stock / factory installed 6.5" driver. It brings bass virtually anywhere in a car: in front doors, rear doors, dash board, center console, under seats, rear decks, and in any space less than 2" deep.

SWS-8" RECOMMENDED ENCLOSURE DESIGNS

The SWS-8 woofer is designed to bring bass virtually anywhere in a car: in front doors, rear doors, dash board, center console, under seats, rear decks, and in any space 2 1/2" deep. The "shallow" enclosures shown below are created to give you "deep bass from the shallowest space".

Sealed Shallow

- Outer dimension shown
- Using 5/8" MDF

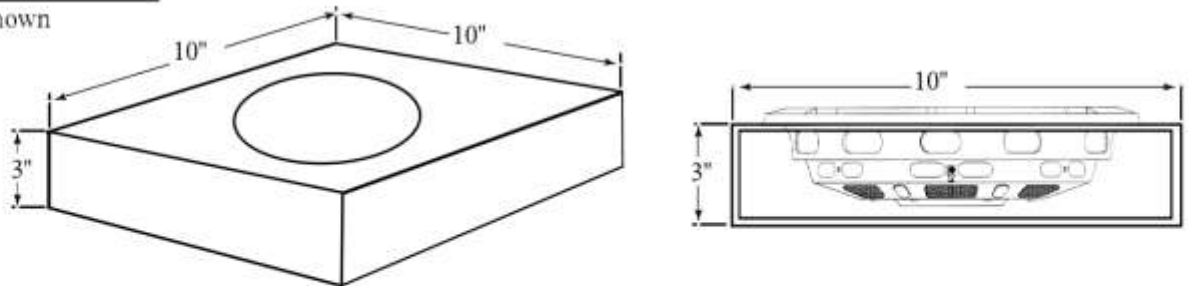

Horn Loaded Shallow

- Outer dimension shown
- Using 5/8" MDF

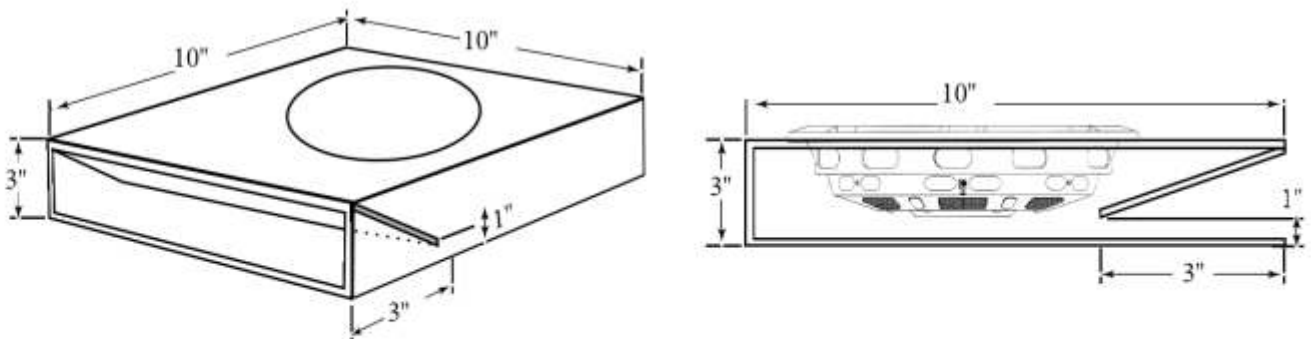

Behind Seat Application

- Outer dimension shown
- Using 5/8" MDF

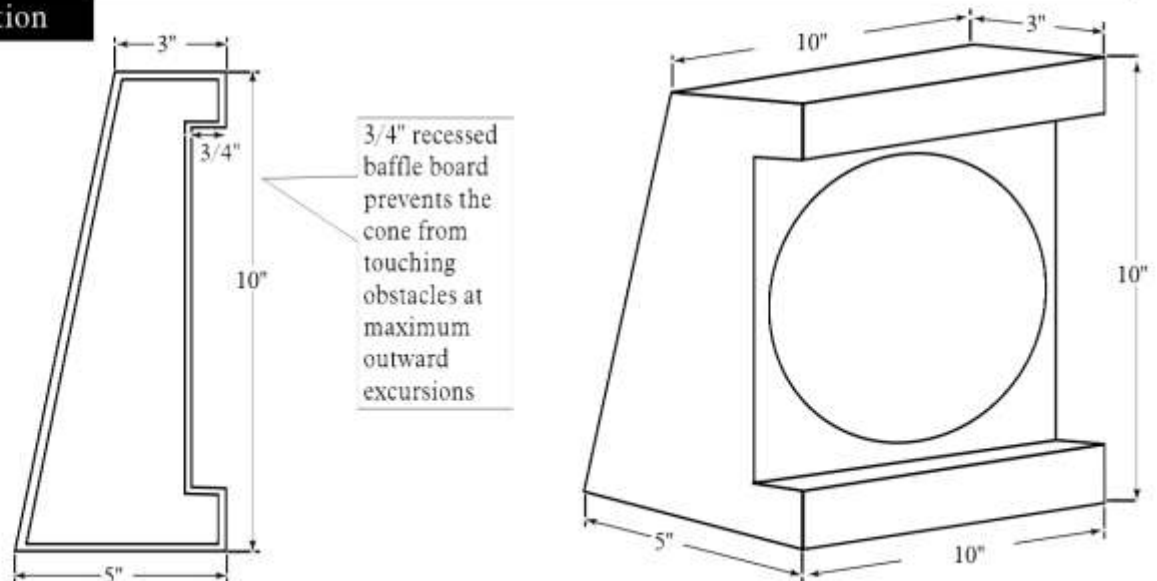

Actual RMS power varies based on box design and on music played

SWS-10" RECOMMENDED ENCLOSURE DESIGNS

The following SWS-10 enclosures are especially designed to fit in shallow spaces. While bass performance is optimized in enclosures with deeper design, the "shallow" enclosures shown below are created to give you "deep bass from the shallowest space".

Minimum Sealed Shallow

- Door Mount application
- Outer dimension shown
- Using 5/8" MDF

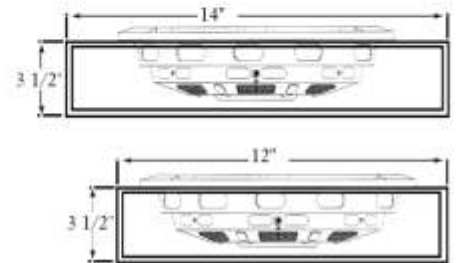
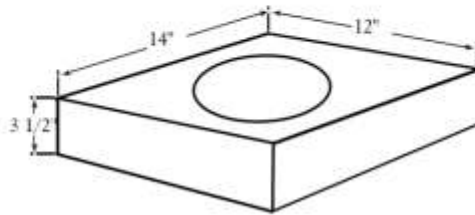

Maximum Sealed Deep

- Outer dimension shown
- Using 5/8" MDF

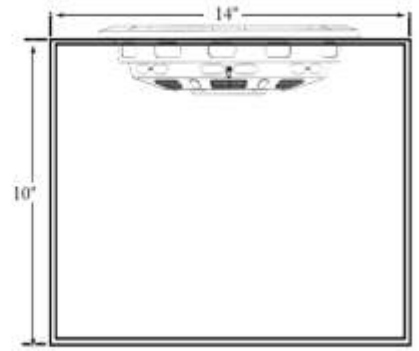
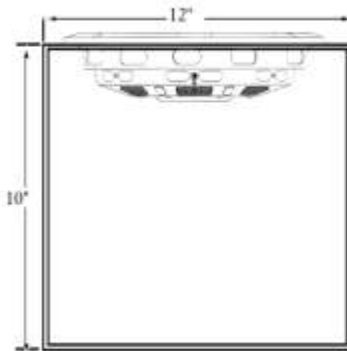
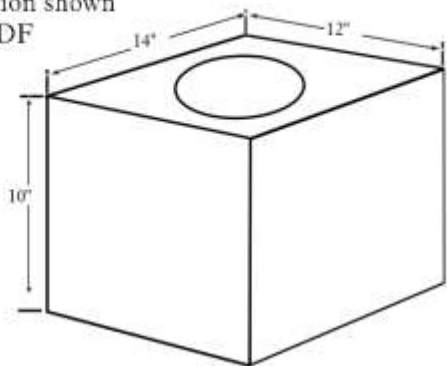

Horn Loaded Shallow

- Under the seat application
- Outer dimension shown
- Using 5/8" MDF

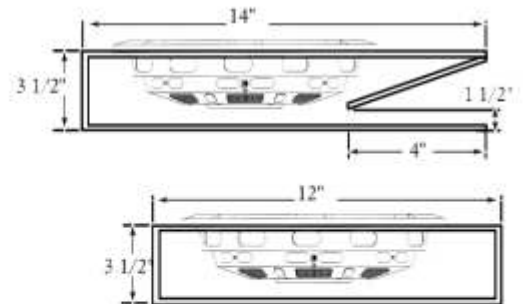
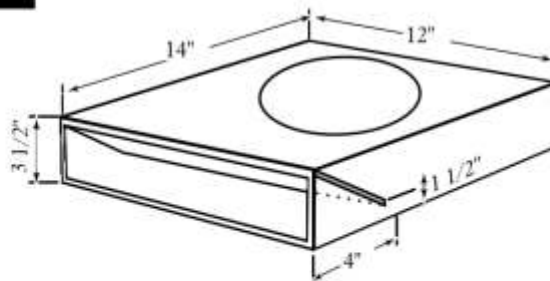

Behind Seat Application

- Under the seat application
- Outer dimension shown
- Using 5/8" MDF



1" recessed baffle board prevents the cone from touching obstacles at maximum outward excursions

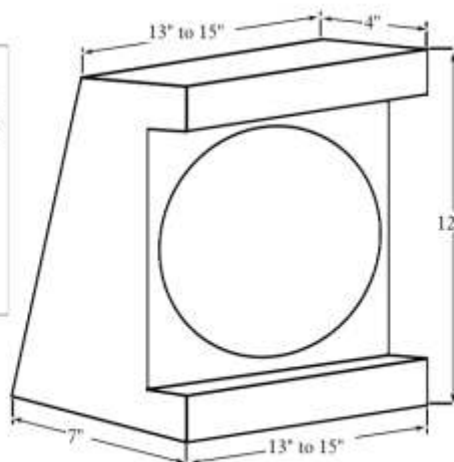

More Sealed Design

Internal box volume = 0.6 cubic feet
 $F_3 = 54\text{Hz}$
 $F_c = 75\text{Hz}$
 $Q = 1.2$
 Ripple = 2.5dB

More Ported Design

Internal box volume = 0.8 cubic feet
 $F_b = 45\text{Hz}$
 $F_3 = 57\text{Hz}$
 Port = 3" (D) x 6" (L)
 Ripple = 3dB

Actual RMS power varies based on box design and on music played

SWS-12" RECOMMENDED ENCLOSURE DESIGNS

The following SWS-12 enclosures are especially designed to fit in shallow spaces. While bass performance is optimized in enclosures with deeper design, the "shallow" enclosures shown below are created to give you "deep bass from the shallowest space".

Minimum Sealed Shallow

- Door Mount application
- Outer dimension shown
- Using 5/8" MDF

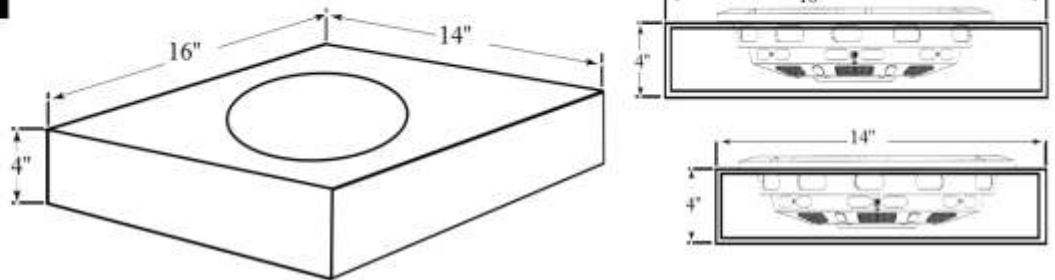

Maximum Sealed Deep

- Outer dimension shown
- Using 5/8" MDF

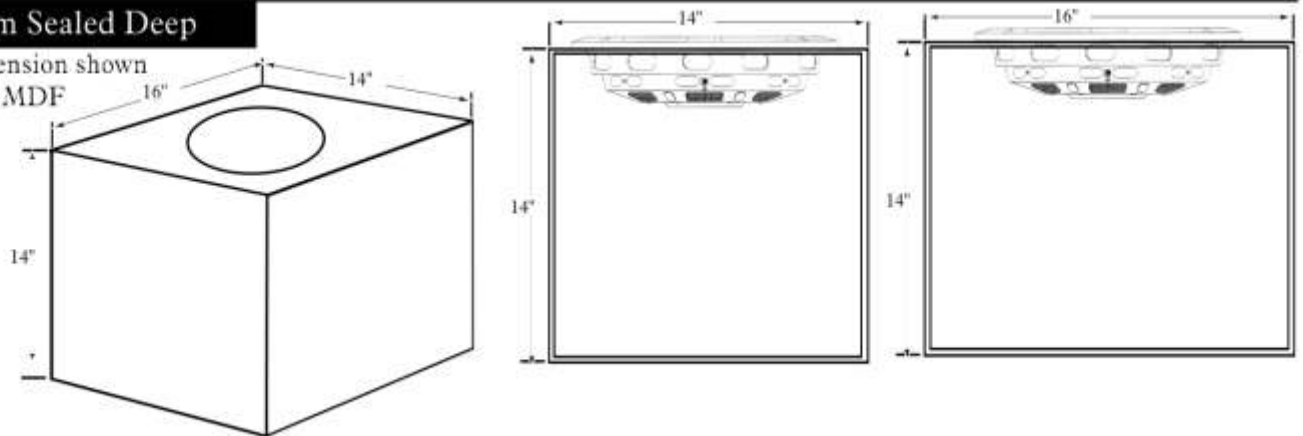

Horn Loaded Shallow

- Under the seat application
- Outer dimension shown
- Using 5/8" MDF

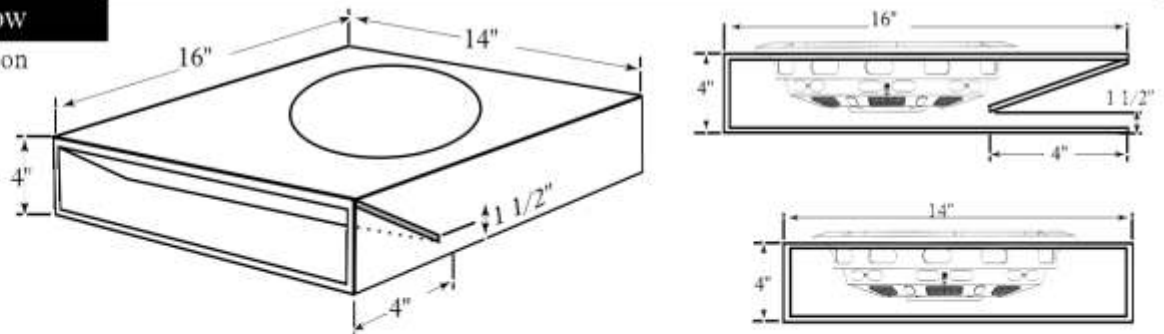

Behind Seat Application

- Under the seat application
- Outer dimension shown
- Using 5/8" MDF

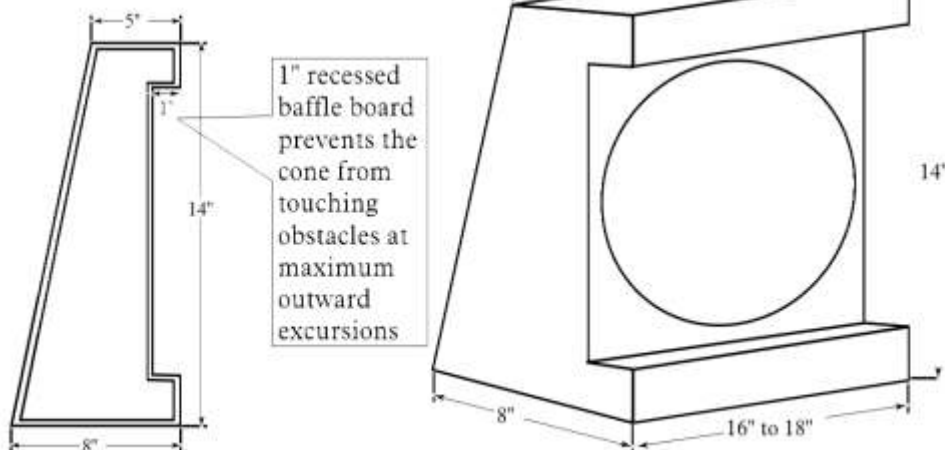

More Sealed Design

Internal box volume = 0.8 cubic feet
 $F_3 = 53\text{Hz}$
 $F_c = 73\text{Hz}$
 $Q = 1.2$
 Ripple = 2.5dB

More Ported Design

Internal box volume = 1 cubic feet
 $F_b = 44\text{Hz}$
 $F_3 = 55\text{Hz}$
 Port = 3" (D) x 7" (L)
 Ripple = 5dB

Actual RMS power varies based on box design and on music played

SWS-15" RECOMMENDED ENCLOSURE DESIGNS

The following SWS-15 enclosures are especially designed to fit in shallow spaces. While bass performance is optimized in enclosures with deeper design, the "shallow" enclosures shown below are created to give you "deep bass from the shallowest space".

Minimum Sealed Shallow

- Door Mount application
- Outer dimension shown
- Using 5/8" MDF

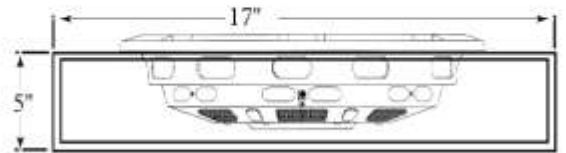
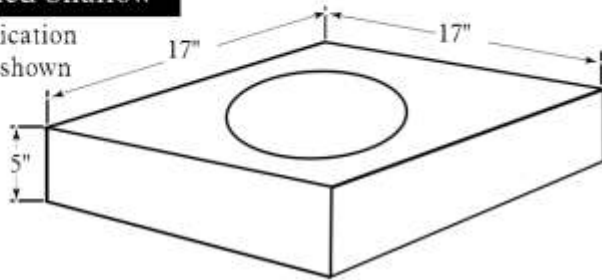

Maximum Sealed Deep

- Outer dimension shown
- Using 5/8" MDF

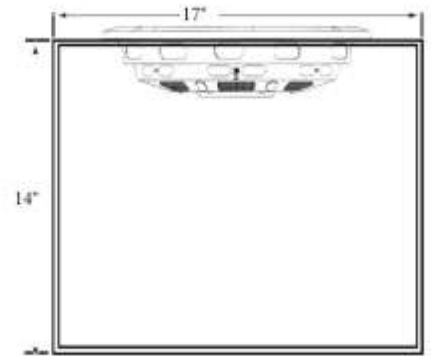
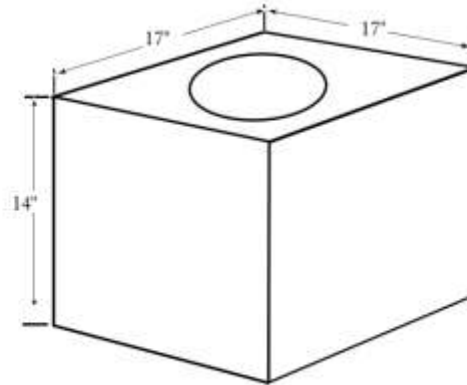

Horn Loaded Shallow

- Under the seat application
- Outer dimension shown
- Using 5/8" MDF

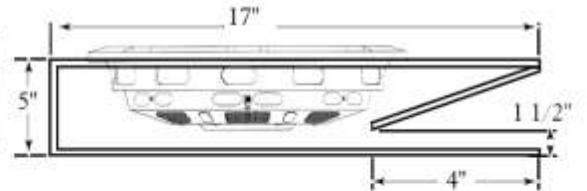
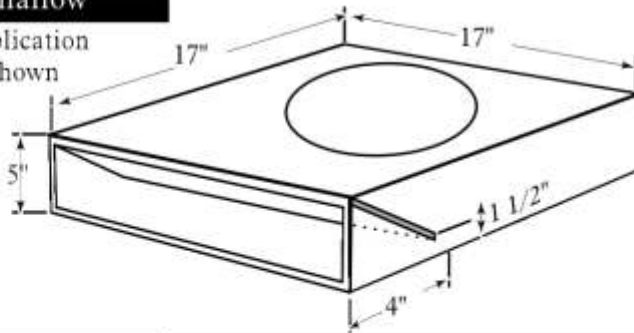

Behind Seat Application

- Under the seat application
- Outer dimension shown
- Using 5/8" MDF

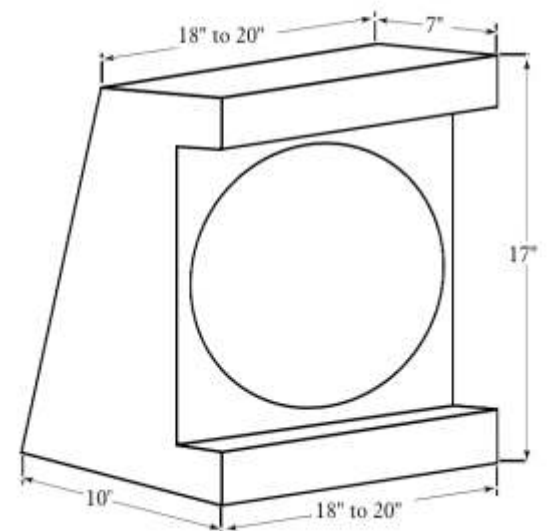
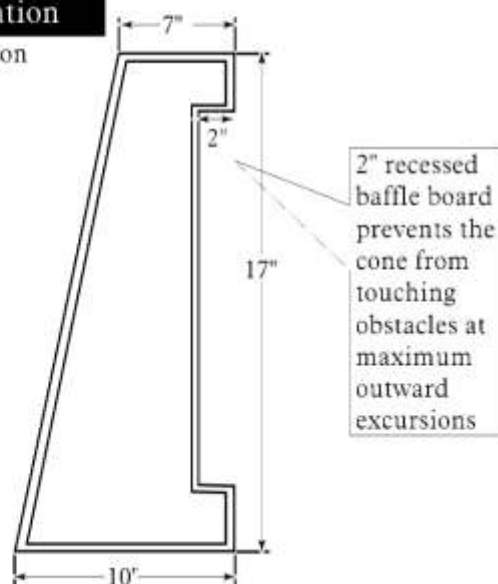

Actual RMS power varies based on box design and on music played